

TLP210 CANopen

ACCELEROMETER

MEMS technology acceleration sensor



L.4 - DS0030 R00 TLP210 CANopen



CHARACTERISTICS

- MEMS technology
- High protection level and wide temperature range
- High temperature stability
- Resolution 1mg



ADVANTAGES

- Excellent accuracy
- Reliability and long service life for outdoor applications
- Compact dimensions
- Designed for harsh environmental conditions



High protection level



Shock/vibration resistant

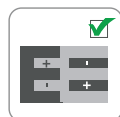

Reverse polarity protection

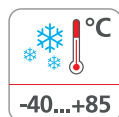

Wide temp. range

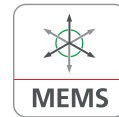

MEMS sensors technology



CANopen output



High accuracy

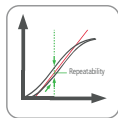

High repeatability



Directive 2011/65/EU



EU conformity

The company reserves the right to make any kind of design or functional modification at any moment without prior notice.

TLP210 CANopen

ACCELEROMETER

MEMS technology acceleration sensor



PRODUCT DESCRIPTION

An accelerometer measures the linear acceleration to the direction of one or more sensitive axes.

TLP210 is the new family of tri-axial acceleration sensors, based on the MEMS technology, capable of working in extreme conditions and hard environments, subjected to sharp movements, shocks and high vibrations.

The high bandwidth enables fast motion detection with very high accuracy and makes it suitable for vibration measurements, active vibration damping, load cells compensation of vibration and preventive maintenance.

Ideal for use on mobile machines such as: agricultural machinery, rotating machinery, hydraulic cranes, aerial platforms, operating and earth moving machines.



L.4 - D50030 R00 TLP210 CANopen



Agricultural machinery



Construction



Earth moving



Handling and lifting

TLP210 CANopen

ACCELEROMETER

MEMS technology acceleration sensor



PRODUCT CODE



- a** Power supply range
2 ◀ = 9 ... 30 V DC
- b** Axis type
Z ◀ = Triaxial
- c** Measurement range
02 ◀ = ±2g
04 ◀ = ±4g
08 ◀ = ±8g
16 ◀ = ±16g
- d** Output type
6 ◀ = CANopen
- e** Connections
1 ◀ = Male connector M12, 5-pin PUR cable 30cm
- f** Architecture⁽²⁾
S ◀ = Single tilt sensor
R ◀ = Redundant tilt sensor

L.4 - DS0030 R00 TLP210 CANopen

(1) Not all combinations can be ordered. Please contact TSM for confirmation before placing an order.
 (2) Redundanted primary measures, acquired by a single logical unit and published on the CANOpen output by one or more PDOs, according to the selected mapping.

TLP210 CANopen

ACCELEROMETER

MEMS technology acceleration sensor



TECHNICAL SPECIFICATION

Measuring range	Up to $\pm 16g$
Linearity	$\pm 0.1g$
Resolution	1mg
Zero-g level ($T_a = 25^\circ C$)	± 40 mg
Temperature drift	Offset: ± 0.1 mg/ $^\circ C$ typ. Sensitivity: ± 0.01 %/ $^\circ C$ typ.
Protection class	IP67 (acc. to EN 60529)
Temperature range	$-40^\circ C \dots +85^\circ C$
Housing	Glass fiber reinforced polyamide
Weight approx.	50 g
Shock resistance	acc. to EN 60068-2-27 50 G, 11 ms, 100 shocks per axis Axis : X, Y, Z
Vibration resistance	acc. to EN 60068-2-6 10 ... 500 Hz, 10g, 2h per axis Axis : X, Y, Z

ELECTRICAL CHARACTERISTICS

Power supply range	See order code
Consumption typ.	30 mA (12 VDC, w/o load) 15 mA (24 VDC, w/o load)
Startup time	< 1.5 s
Interface	CANopen
CANopen profile conformity	CiA DS301
Electromagnetic compatibility	acc. to EN 61326-1, EN 61326-3-1
EU conformity	EMC directive 2014/30/EU RoHS directive 2011/65/EU + 2015/863/EU

ELECTRICAL CONNECTION M12 X 5 PINS

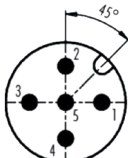
	Pinout
1	CAN-GND*
2	+Vin
3	GND*
4	CAN-H
5	CAN-L
* GND and CAN_GND terminals are internally connected to each other and identical in their function	

OPERATING PRINCIPLE

MEMS, or Micro Electro-Mechanical System, is a chip-based technology where sensors are composed of proof masses sprung between capacitive plates. Each mass act like a moving plate of a variable capacitor formed by an array of interlaced 'fingers'.

If the sensor is subjected to an external acceleration, the mass moves changing the distance between the plates and therefore the capacitance. By measuring the capacitance variation the external acceleration can be detected.

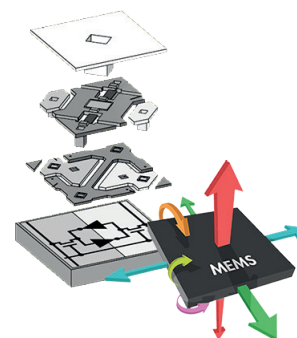

L.4 - DS0030 R00 TLP210 CANopen

TLP210 CANopen

ACCELEROMETER

MEMS technology acceleration sensor



SENSIBLE AXES

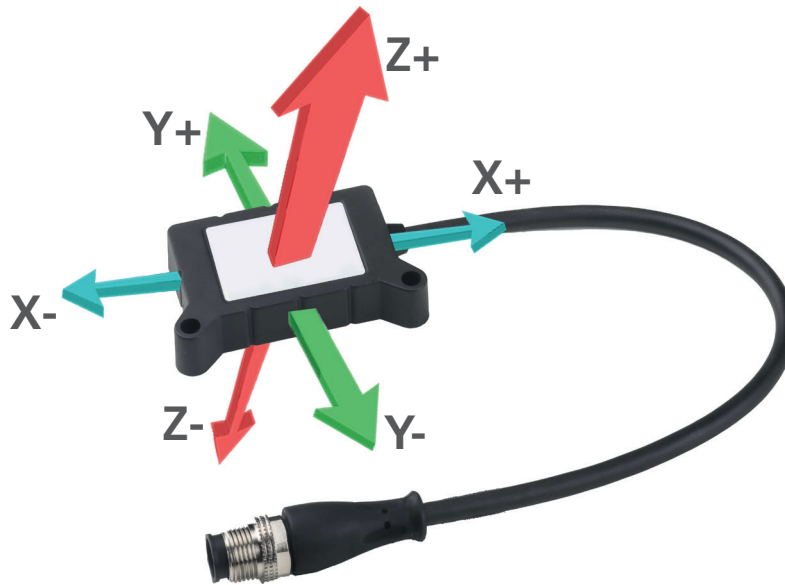

L.4 - DS0030 R00 TLP210 CANopen



DIMENSIONS [mm]

