

# MAG200 Analog

## MAGNETOSTRICTIVE SENSOR

Absolute measuring length up to 2.5 m linear position transducer



L.4 - DS0040 R02 MAG200 Analog - 20/03/26



### CHARACTERISTICS

Measuring range up to 2.5 m
Designed for installation into hydraulic cylinders
High shock and vibration resistance
M18x1.5 threaded connection
Operating pressure up to 350 bar
Customizable cursor



### ADVANTAGES

Absolute contactless linear position measurement
High resolution and linearity
Unlimited mechanical life
Rod, nipple and flange in AISI 316
Easy installation and field replacement
Position, speed and acceleration measurement



High protection level



Shock/vibration resistant

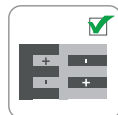

Reverse polarity protection

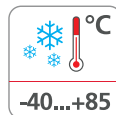

Wide temp. range

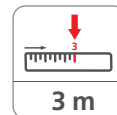

Max. length: 3 m



Analog output



High accuracy



Directive 2011/65/EU



EU conformity

The company reserves the right to make any kind of design or functional modification at any moment without prior notice.

# MAG200 Analog

## MAGNETOSTRICTIVE SENSOR

Absolute measuring length up to 2.5 m linear position transducer



### PRODUCT DESCRIPTION

MAG200 is a magnetostrictive position transducer with threaded connection, designed for mobile machines which can be installed inside oil-pressure cylinders.

The only external part is the head whose slim profile facilitates installation in confined spaces and allows easy maintenance operations. Its unique design, plus a wide range of cursor configurations, ensure easy installation and full compatibility with cylinder manufacturer specifications.

The temperature range from -40 to +85°C, the operating pressures up to 350 bar and the high resistance to vibration and shock make the sensor very robust, a fundamental feature in heavy-duty applications. High performance in terms of transduction of measurement defined as linearity, hysteresis and repeatability.



**Agricultural machinery**



**Construction**



**Earth moving**



**Handling and lifting**

L.4 - DS0040 R02 MAG200 Analog - 20/03/26

# MAG200 Analog

## MAGNETOSTRICTIVE SENSOR

Absolute measuring length up to 2.5 m linear position transducer



### PRODUCT CODE

ORDER CODE<sup>(1)</sup>
▶
M A G 2 0 0 .

a

b

c

d

e

f

g

h

**a** Power supply range

**2** ◀ = 9 ... 30 V DC (only for outputs 2; 33; 32; 34)

**3** ◀ = 12 ... 30 V DC (only for outputs 7; 35; 4; 41)

**b** Active stroke range

**XXXX** ◀ = mm (steps of 0100 mm)

**c** Dead zone

**20** ◀ = 20 mm only for backwards compatibility

**36** ◀ = 36 mm for 0 to 1200mm strokes

**63** ◀ = 63 mm for 1201 to 2500mm strokes

**d** Output type

**2** ◀ = 0,5...4,5 VDC

**33** ◀ = 4,5...0,5 VDC

**32** ◀ = 0,25...4,75 VDC

**34** ◀ = 4,75...0,25 VDC

**7** ◀ = 4...20 mA

**35** ◀ = 20...4 mA

**4** ◀ = 0...10 VDC

**41** ◀ = 1...9 VDC

**e** Connections

**25** ◀ = Male flange connector M12, 4-pin

**27** ◀ = Male flange connector M12, 8-pin

**f** Cursor type

**X** ◀ = none

**0** ◀ = Magnetic cursor 18 x 8 mm - AW2011A anodized

**1** ◀ = Magnetic cursor 18 x 10 mm - AW2011A anodized

**g** Customization

**X** ◀ = None

**?** ◀ = Customization code

**h** Approvals

**1** ◀ = Standard components<sup>(2)</sup>

(1) Not all combinations can be ordered. Please contact TSM for confirmation before placing an order.

(2) Standard component. It does not constitute a safety component as defined in the Machinery Directive 2006/42/CE.

# MAG200 Analog

## MAGNETOSTRICTIVE SENSOR

Absolute measuring length up to 2.5 m linear position transducer



### TECHNICAL SPECIFICATION

Measuring range	0.1...2.5 m
Magnetostrictive resolution	0.1 mm
Magnetostrictive linearity (Ta = 25°C)	up to 250mm <math>\pm 0.1\text{ mm}</math> from 250 to 2500mm $\pm 0.04\%$ FS
Magnetostrictive repeatability (Ta = 25°C)	$\pm 0.1\text{ mm}$
Operating pressure	According to EN 13480-5 350 bar (Peak: 500 bar)
Protection class	IP67
Temperature range	-40°C ... +85°C
Temperature coefficient	$\pm 0.004\%$ FS/°C
Housing	Head and rod: stainless steel AISI316
Rod diameter	10 mm
Shock resistance	acc. to EN 60068-2-27 30 G, 11 ms 100 Shocks per axis
Vibration resistance	acc. to EN 60068-2-6 10 ... 150 Hz

### ELECTRICAL CHARACTERISTICS

Power supply range	see order code
Startup time	200 ms
Inrush current	1.5A - 2ms @ 12VDC
Current consumption. (with load at FS)	Current output: 58 mA (12 VDC); 43 mA (24 VDC) Voltage output: 34 mA (12 VDC); 19 mA (24 VDC)
Load resistor	> 10 kOhm, voltage output type < 500 Ohm, current output type
Electromagnetic compatibility	acc. to EN 61000-6-2, EN 61000-6-4
EU conformity	EMC directive 2014/30/EU RoHS directive 2011/65/EU + 2015/863/EU

### OPERATING PRINCIPLE

The operating principle is based on the magnetostrictive effect. The application of periodic short current pulses in the magnetostrictive wire generates an induced magnetic field. The interaction of the magnetic cursor, connected to the moving object in the application, with this field generates a momentary torsional strain on the magnetostrictive wire which propagates along it as in a waveguide. When the ultrasonic wave reaches the end of the guide, it is detected by a sensitive element which converts it into an electrical signal. Since the velocity of propagation is known, the linear position is computed by measuring the time-of-flight of the pulse.



L.4 - DS0040 R02 MAG200 Analog - 20/03/26

### ELECTRICAL CONNECTION M12 X 4 PINS

<b>Pinout</b>	
1	+Vin
2	n.c.*
3	GND
4	V / I out

### ELECTRICAL CONNECTION M12 X 8 PINS

<b>Pinout</b>			
1	V / I out	5	n.c.*
2	Signal GND	6	GND
3	n.c.*	7	+Vin
4	n.c.*	8	n.c.*



\* = PIN MARKED n.c. MUST NOT BE CONNECTED  
Applying a voltage to this pin can damage the device!

# MAG200 Analog

## MAGNETOSTRICTIVE SENSOR

Absolute measuring length up to 2.5 m linear position transducer

### CURSOR TYPES

#### 1] Magnetic cursor 18 x 10 mm - AW2011 anodized\*\*

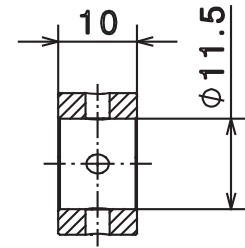
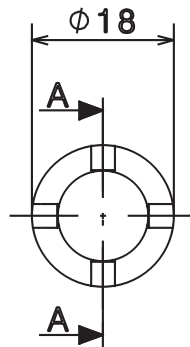
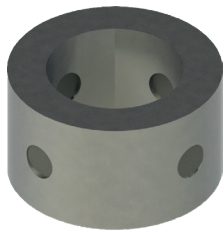

Section A-A

#### 2] Magnetic cursor 18 x 8 mm - AW2011 anodized\*\*

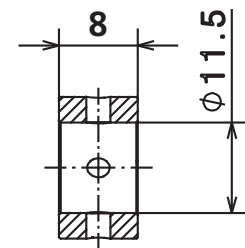
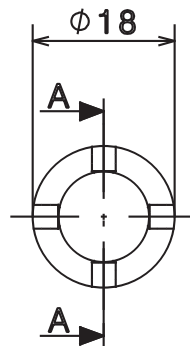
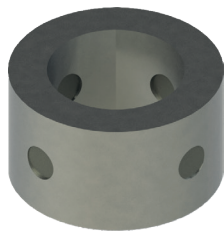

Section A-A

\*\*Do not separate the magnetic cursor from the sensor. For correct operation, each sensor must be mounted in the cylinder with its own supplied cursor.

# MAG200 Analog

## MAGNETOSTRICTIVE SENSOR

Absolute measuring length up to 2.5 m linear position transducer



### DIMENSIONS [mm]

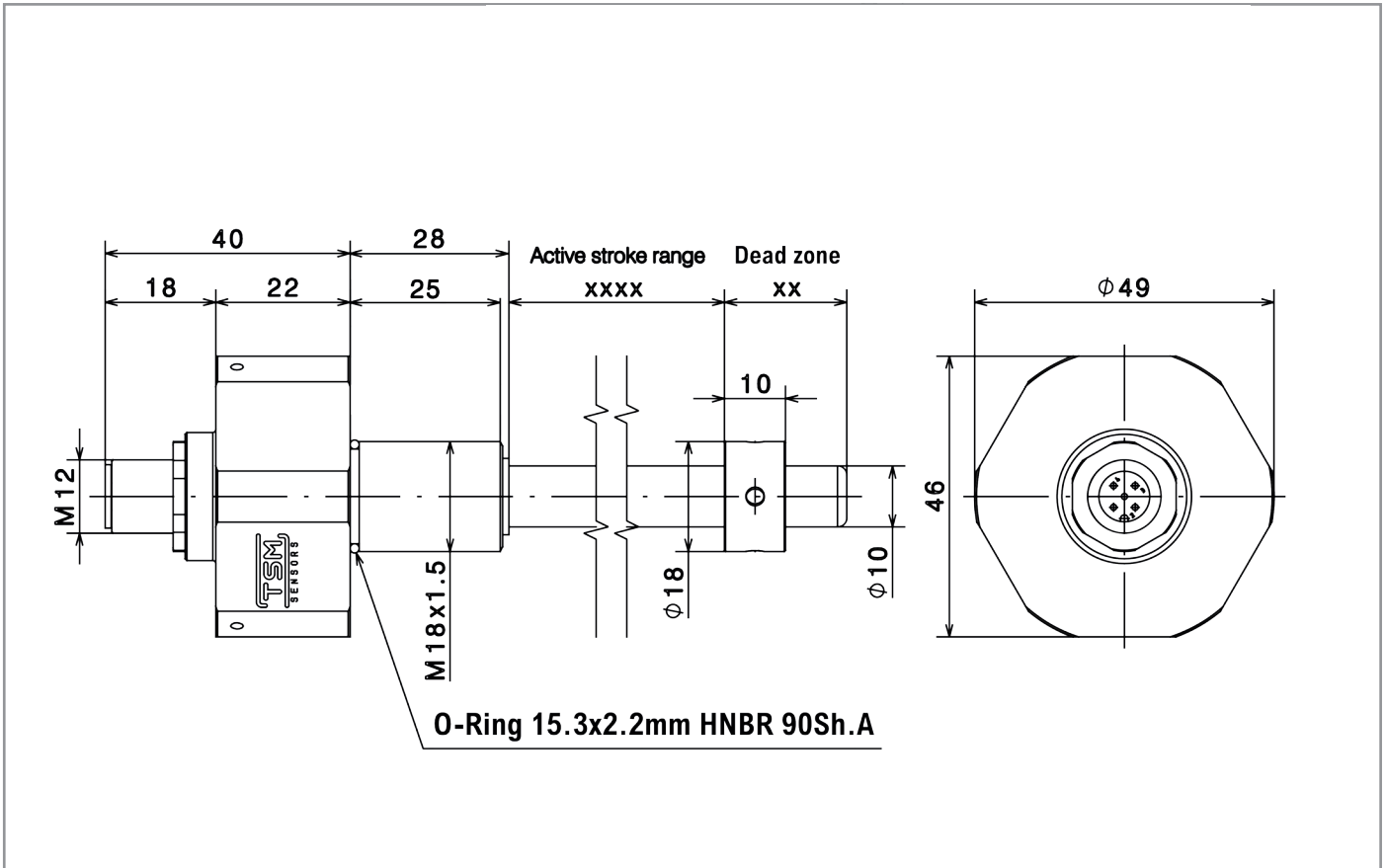

L.4 - DS0040 R02 MAG200 Analog - 20/03/26

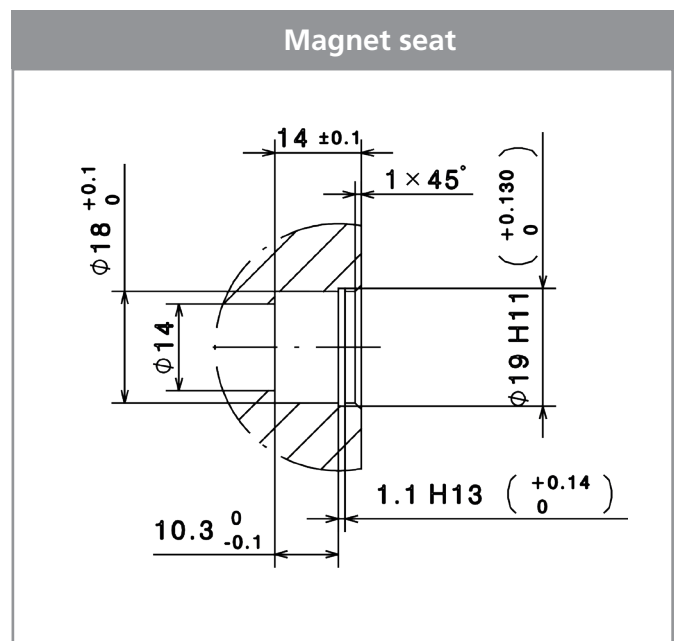
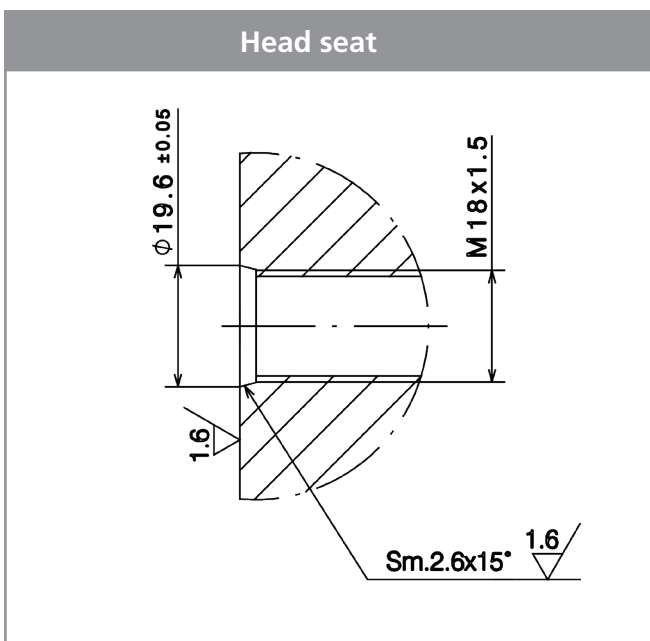

**WARNING:** For installation apply a maximum tightening torque of 60 Nm