

CET.5000 Analog

CABLE EXTENSION TRANSDUCER

Absolute measuring length up to 5 m



L.4 - DS0021 R03 CET.5000 Analog 22/01/2026



CHARACTERISTICS

- Measuring range up to 5 m
- Compact size
- Linearity up to $\pm 0.8\%$ FS
- High protection level and wide temperature range



ADVANTAGES

- The measuring length suitable for every application
- Designed for harsh environmental conditions
- Reliability and long service life for outdoor applications
- Hall effect technology



IP67
High protection level



Shock/vibration resistant

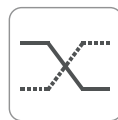

Redundant outputs

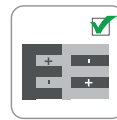

Reverse polarity protection

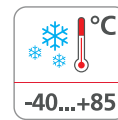

-40...+85
Wide temp. range

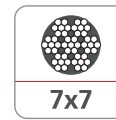

7x7
7x7 stainless steel rope

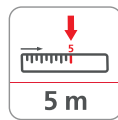

5 m
Max. length: 5 m



500.000
Ultra durable



Analog
Analog output



RoHS compliant
Directive 2011/65/EU



CE
EU conformity

The company reserves the right to make any kind of design or functional modification at any moment without prior notice.

CET.5000 Analog

CABLE EXTENSION TRANSDUCER

Absolute measuring length up to 5 m



PRODUCT DESCRIPTION

CET5 is a robust, high-performance, wire cable pull transducer with analog output, designed for industrial applications and featuring high quality and durability.

Excellent repeatability, high IP rating, shock and vibration resistance and electromagnetic immunity makes this transducer suitable for mobile hydraulic applications such as: agricultural vehicles, earth moving machines, construction equipment, articulated arm cranes and aerial work platforms.



L.4 - DS0021 R03 CET.5000 Analog 22/01/2026



Agricultural machinery



Construction



Earth moving



Handling and lifting

CET.5000 Analog

CABLE EXTENSION TRANSDUCER

Absolute measuring length up to 5 m



PRODUCT CODE

ORDER CODE⁽¹⁾
▶

CET.

a Measurement range

1000 ◀ = 1 m

2000 ◀ = 2 m

3000 ◀ = 3 m

4000 ◀ = 4 m

5000 ◀ = 5 m

b Power supply range

2 ◀ = 9 ... 30 V DC (only for outputs 2; 3; 20; 31)

3 ◀ = 12 ... 30 V DC (only for outputs 4; 7; 22; 35)

c Output type

2 ◀ = 0,5 ... 4,5 V DC

3 ◀ = 0 ... 5 V DC

4 ◀ = 0 ... 10 V DC

7 ◀ = 4 ... 20 mA

20 ◀ = 0,5 ... 4,5 V DC Redundant

31 ◀ = 0 ... 5 V DC Redundant

22 ◀ = 0 ... 10 V DC Redundant

35 ◀ = 4 ... 20 mA Redundant

d Connections

1 ◀ = Male flange connector M12, 5-pin

e Options

X ◀ = None

f Output mode

X ◀ = Direct signals

C ◀ = Crossed signals (only for redundant type)

g Customization

X ◀ = None

? ◀ = Customization code

(1) Not all combinations can be ordered. Please contact TSM for confirmation before placing an order.

CET.5000 Analog

CABLE EXTENSION TRANSDUCER

Absolute measuring length up to 5 m



TECHNICAL SPECIFICATION

Measuring range	1...5m (Linear)
Wire material	AISI304 steel wire with nylon coating \varnothing 0.9 mm
Rope breaking force	typ. 330 N
Wire fastening	Eyelet Inner diameter \varnothing 8 mm Outer diameter \varnothing 15 mm Height 5 mm
Wire pull-out max speed	1 m/s
Cable transducer resolution	15 bit
Cable transducer linearity (Ta = 25°C)	± 0.8 % FS
Cable transducer repeatability (Ta = 25°C)	± 15 mm
Pull-in force	typ. 2 N (pull-in force reduced at low temperatures)
Pull-out force	typ. 8 N
Life cycles (Ta = 25°C) (*)	500.000
Drum circumference	245 mm
Housing	Glass fiber reinforced polycarbonate
Protection class (Electronics compart.)	IP67 (acc. to EN 60529)
Temperature range	-40°C ... +85°C
Weight approx.	0.6 kg
Shock resistance	acc. to EN 60068-2-27 50 G, 11 ms, 100 shocks per axis Axis : X, Y, Z
Vibration resistance	acc. to EN 60068-2-6 10 ... 500 Hz, 10g, 2h per axis Axis : X, Y, Z

OPERATING PRINCIPLE

Construction

The core of a draw wire sensor is a bearings mounted drum on which a wire rope is wound. The unwinding of the rope drives the rotation of the drum, thus the linear displacement of the rope is converted into an angular displacement of the drum. By measuring the angle of the drum, the linear displacement of the wire is detected.

Caution

Exceeding the maximum extension length of the draw wire will lead to damage to the wire and the mechanics.

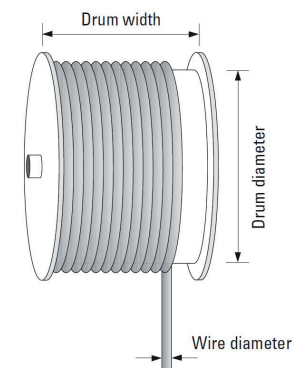

ELECTRICAL CHARACTERISTICS

Power supply range	See order code
Consumption typ. (with load at FS)	<u>Current output:</u> Single: 35 mA (12 VDC); 28 mA (24 VDC) Redundant: 65 mA (12 VDC); 54 mA (24 VDC) <u>Voltage output:</u> Single: 16 mA (12 VDC); 9 mA (24 VDC) Redundant: 30 mA (12 VDC); 17 mA (24 VDC)
Startup time	< 400ms
Load resistor	> 10 kOhm, voltage output type < 500 Ohm, current output type
Electromagnetic compatibility	acc. to EN 61000-6-2, EN 61000-6-3
EU Conformity	EMC directive 2014/30/EU RoHS directive 2011/65/EU + 2015/863/EU

ELECTRICAL CONNECTION M12 X 5 PINS

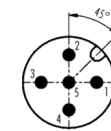

Pinout

1	+Vin
2	n.c.*
3	GND
4	V / I out 1
5	V / I out 2 (only for redundant versions)

* = PIN MARKED n.c. MUST NOT BE CONNECTED
Applying a voltage to this pin can damage the device!

(*) Specified for 20–80% FS operating cycles.

CET.5000 Analog

CABLE EXTENSION TRANSDUCER

Absolute measuring length up to 5 m



DIMENSIONS [mm]

