

CET20 CANopen

CABLE EXTENSION TRANSDUCER

Absolute measuring length up to 20 m with integrated inclinometer



L.4 - DS0017 R06 CET20 CANopen 22/01/2026



CHARACTERISTICS

Measuring range up to 20 m
Angle and length redundant sensors
Compact size
Linearity up to $\pm 0.6\%$ FS
High protection level and wide temperature range



ADVANTAGES

The measuring length suitable for every application
Designed for harsh environmental conditions
Reliability and long service life for outdoor applications
Firmware upgradable via proprietary bootloader
Hall effect technology



High protection level



Shock/vibration resistant

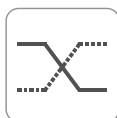

Redundant outputs

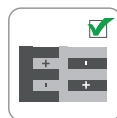

Reverse polarity protection

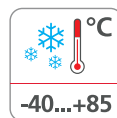

Wide temp. range

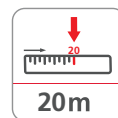

Max. length: 20m



Ultra durable



Dynamic Inclinometer



CANopen output



CANopen Safety

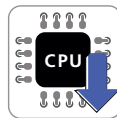

Firmware Upgradable



Directive 2011/65/EU



EU conformity

The company reserves the right to make any kind of design or functional modification at any moment without prior notice.

CET20 CANopen

CABLE EXTENSION TRANSDUCER

Absolute measuring length up to 20 m with integrated inclinometer



PRODUCT DESCRIPTION

CET20 is a robust, high-performance, wire cable pull transducer with CANopen output, designed for industrial applications and featuring high quality and durability.

Excellent repeatability, high IP rating, shock and vibration resistance and electromagnetic immunity makes this transducer suitable for mobile hydraulic applications such as: agricultural vehicles, earth moving machines, construction equipment, articulated arm cranes and aerial work platforms.



L.4 - DS0017 R06 CET20 CANopen 22/01/2026



Agricultural machinery



Construction



Earth moving



Handling and lifting

CET20 CANopen

CABLE EXTENSION TRANSDUCER

Absolute measuring length up to 20 m with integrated inclinometer



PRODUCT CODE

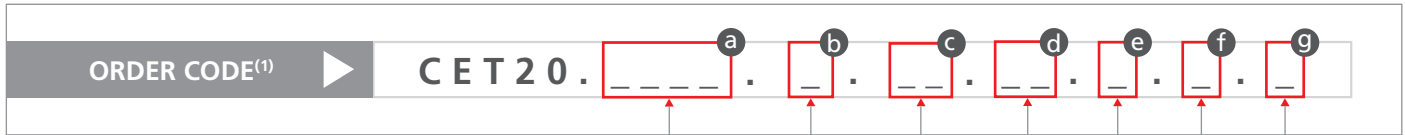

a Measurement range

20000 ◀ = 20 m

b Power supply range

2 ◀ = 9 ... 30 V DC

6 ◀ = 8 ... 36 V DC

c Output type

6 ◀ = CANopen

43 ◀ = CANopen safety

d Connections

1 ◀ = Male flange connector M12, 5-pin

13 ◀ = Deutsch DT04-6P, PUR cable 70cm

36 ◀ = Deutsch DT04-6P, PUR cable 70cm +120 Ohm

e Architecture⁽²⁾

X ◀ = Redundant linear sensors

IR ◀ = Redundant linear & tilt sensors

f Customization

X ◀ = None

? ◀ = Customization code

g Approvals

1 ◀ = Standard components⁽³⁾

2 ◀ = SIL2/PLd

L.4 - DS0017 R06 CET20 CANopen 22/01/2026

(1) Not all combinations can be ordered. Please contact TSM for confirmation before placing an order.

(2) Redundant primary measures, acquired by a single logical unit and published on the CANOpen output by one or more PDOs, according to the selected mapping.

(3) Standard component. It does not constitute a safety component as defined in the Machinery Directive 2006/42/CE.

CET20 CANopen

CABLE EXTENSION TRANSDUCER

Absolute measuring length up to 20 m with integrated inclinometer



TECHNICAL SPECIFICATION

Measuring range	20m (linear) +3mt extra wire ; 0 ... 359.9° (angle)
Wire material	AISI304 steel wire ø 1 mm
Rope breaking force	typ. 350 N
Wire pull-out max speed	max. 1 m/s
Cable transducer resolution	0.1 mm
Cable transducer linearity (Ta = 25°C)	±0.6 % FS
Cable transducer repeatability (Ta = 25°C)	±0.6 % FS
Inclinometer resolution	0.1 °
Inclinometer accuracy (Ta = 25°C)	±0.3 °
Inclinometer temperature drift	±0.01 °/°C typ.
Pull-in force	typ. 7 N (pull-in force reduced at low temperatures)
Pull-out force	typ. 14 N
Life cycles (Ta = 25°C) ^(*)	250.000
Drum circumference	565 mm
Housing	Carbon steel, PE
Protection class (Electronics compart.)	IP66 (acc. EN 60529)
Temperature range	-40°C ... +85°C
Weight approx.	5 kg
Shock resistance	acc. to EN 60068-2-27 50 G, 11 ms, 100 shocks per axis Axis : X, Y, Z acc. to ISO 19014-3:2018 (test method EN 60068-2-27) 30 G, 18 ms, 6 shocks per axis Axis : X, Y, Z
Vibration resistance	acc. to EN 60068-2-6 10 ... 500 Hz, 10 G, 2h per axis Axis : X, Y, Z acc. to ISO 19014-3:2018 (test method EN 60068-2-64) 10 ... 2000 Hz, PSD 0.05 ... 2, >8h per axis Axis : X, Y, Z



ELECTRICAL CHARACTERISTICS

Power supply range	See order code
Consumption typ.	42 mA (12 VDC, w/o load) 21 mA (24 VDC, w/o load)
Startup time	< 1.5 s
Interface	CANopen CANopen Safety
CANopen profile conformity	CiA DS301
Electromagnetic compatibility	acc. to EN 61326-1, EN 61326-3-1 acc. to ISO 19014-3:2018 (test method ISO 13766-1, ISO 13766-2)
EU Conformity	EMC directive 2014/30/EU UNECE Reg. 10 R06 (**) RoHS directive 2011/65/EU + 2015/863/EU

(*) Specified for 20–80% FS operating cycles.

(**) Valid only for 8 ... 36 V DC version.



OPERATING PRINCIPLE

Construction

The core of a draw wire sensor is a bearings mounted drum on which a wire rope is wound. The unwinding of the rope drives the rotation of the drum, thus the linear displacement of the rope is converted into an angular displacement of the drum. By measuring the angle of the drum, the linear displacement of the wire is detected.

Caution

Exceeding the maximum extension length of the draw wire will lead to damage to the wire and the mechanics.

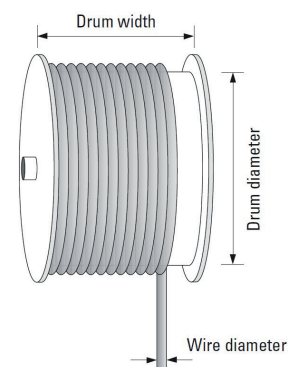

CET20 CANopen

CABLE EXTENSION TRANSDUCER

Absolute measuring length up to 20 m with integrated inclinometer



ELECTRICAL CONNECTION M12 X 5 PINS

Pinout

1	CAN-GND*
2	+Vin
3	GND*
4	CAN-H
5	CAN-L

* GND and CAN_GND terminals are internally connected to each other and identical in their function

ELECTRICAL CONNECTION DEUTSCH DT04-6P

Pinout

1	+Vin
2	GND
3	CAN H
4	CAN L
5	n.c.**
6	n.c.**

** PIN MARKED n.c. MUST NOT BE CONNECTED



ANGLE SENSOR

CET20 can be ordered with the optional integrated angle sensor.

The single axis tilt sensor allows to detect the angular change around the axis perpendicular to the installation plane. Several user settings are available, such as:

- Output range selection $\pm 180^\circ$ and $0 \dots 360^\circ$
- Direction of rotation (CW/CCW)
- Zero point setting (Preset/Offset)
- Output filter bandwidth

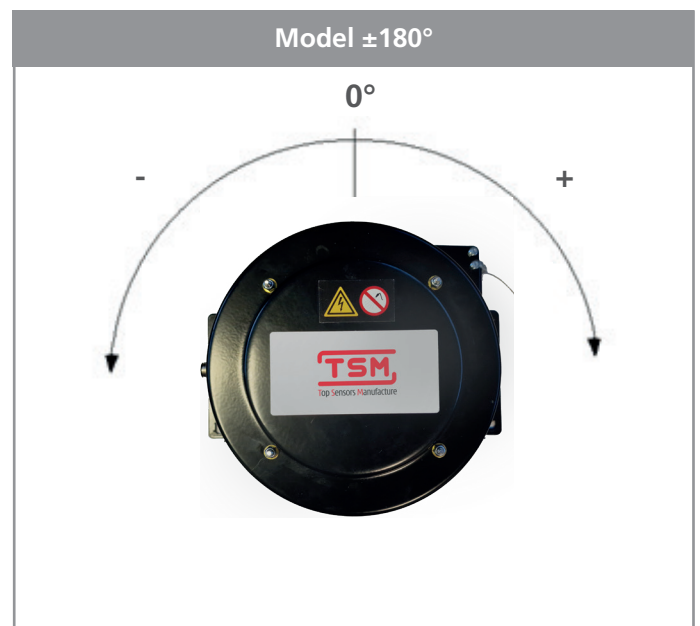
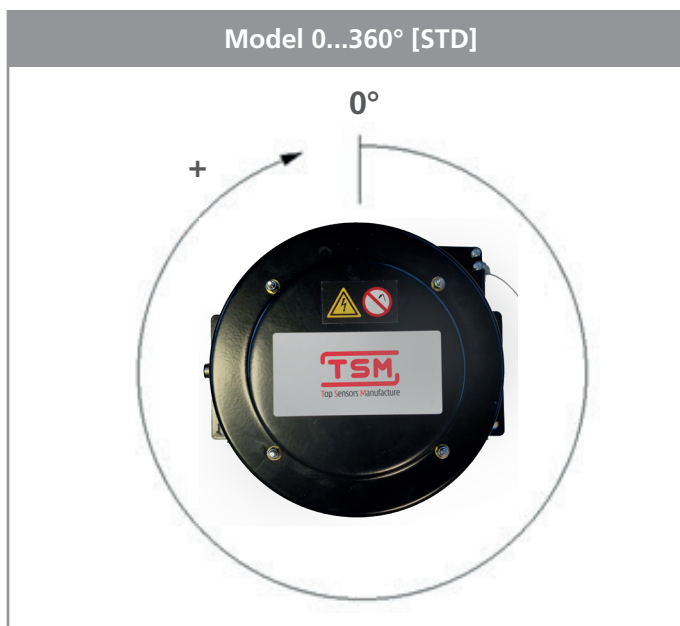

CET20 CANopen

CABLE EXTENSION TRANSDUCER

Absolute measuring length up to 20 m with integrated inclinometer



DIMENSIONS [mm]

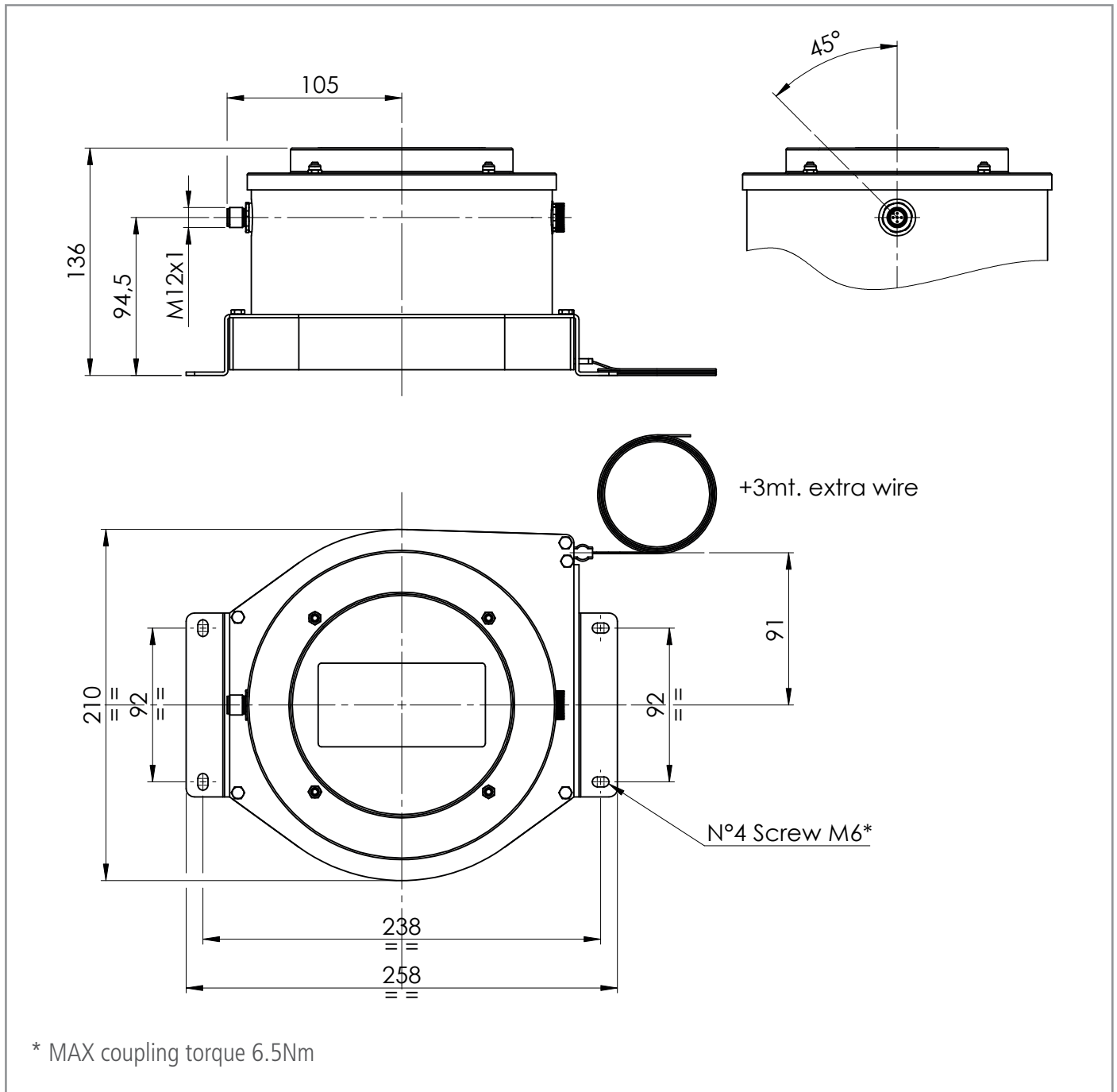

L.4 - DS0017 R06 CET20 CANopen 22/01/2026